



Passion for packaging

lipBio



COMPOSTABLE* & BIODEGRADABLE PRODUCTS

lipBio

**Quality that
renews itself.**



TO GET THINGS STRAIGHT...

compostable or biodegradable ?

These two terms, often confused for synonyms, in fact have a substantial difference that must be known in order to avoid errors when making **separate waste collection**.

The difference lies in time. **A biodegradable element is in fact not automatically compostable.**

To clarify, let's start from the definition: **biodegradable** is defined as any material that can be broken down by bacteria, sunlight and other natural physical agents into simple chemical compounds such as water, carbon dioxide and methane. A process that involves a multitude of materials, and that can be of long degradation, depending on the material. However, the European norm **EN 13432:2002** establishes that to be defined as biodegradable, a product must decompose to 90% within **6 months**.

Instead, it is defined **compostable** (transformable into compost, a natural fertilizer) that material which is not only biodegradable but also disintegrating and whose decomposition process takes place in **less than 3 months**.

biobased %



BIOBASED= made wholly or to a significant part from biomass, renewable (non-fossil) resource.

Just because a plastic product is biobased does not necessarily mean the product is biodegradable or compostable

TO GET THINGS STRAIGHT...

EN 13432

The European norm **EN 13432** is a harmonized standard of the European Standardization Committee relating to characteristics that a material must possess in order to be able to define itself biodegradable or compostable. The term "compostable" refers to rules related to the non-toxicity of the decomposed material if dispersed in nature.

According to EN 13432, a **material to be defined as "compostable", must have the following characteristics:**

- degrade at least 90% in 6 months if subjected to an environment rich in carbon dioxide
- if in contact with organic materials for a period of 3 months, at least 90% of the mass of the material must be made up of fragments smaller than 2 mm
- the material must not have negative effects on the composting process
- low concentration of heavy metals added to the material
- pH values within the established limits
- saline content within the established limits
- concentration of volatile solids within the established limits
- concentration of nitrogen, phosphorus, magnesium and potassium within the established limits



TO SPECIFY...

COMPOSTABILITY'

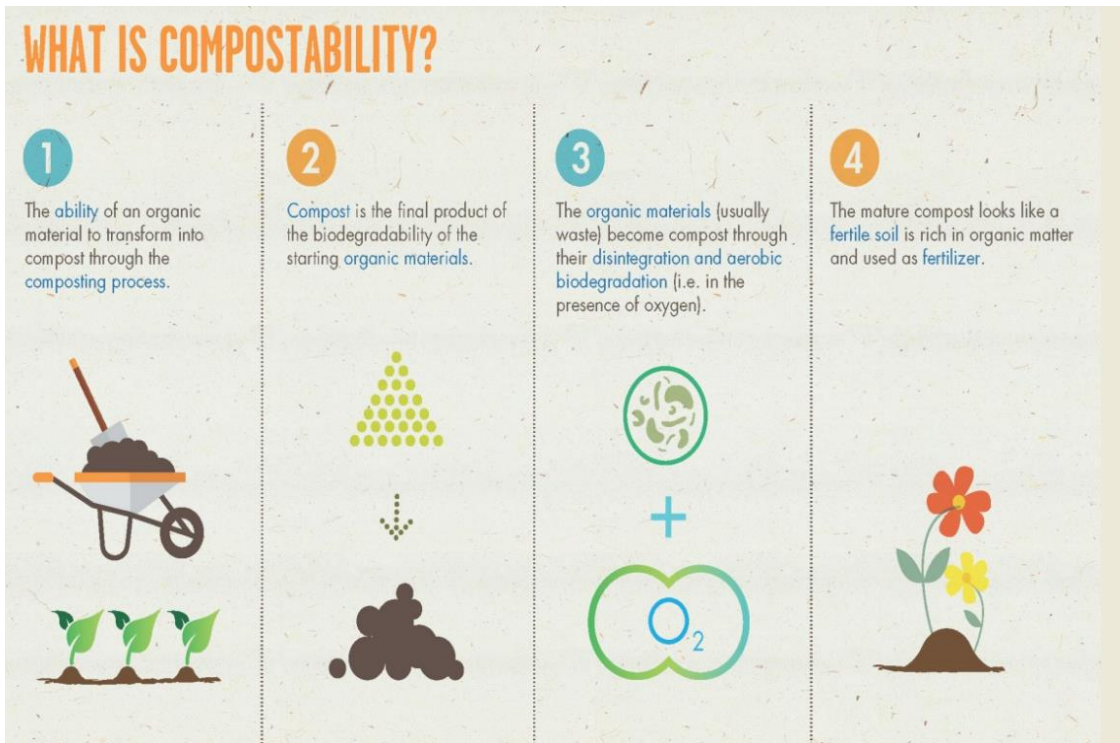

DECLARED **COMPOSTABLE PRODUCTS** SHOULD REPORT ON THE PACKAGE THE LOGO OF THE COMPOSTABILITY CERTIFICATION AND ITS LICENSE NUMBER.

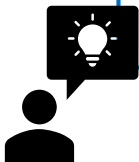

TO SPECIFY...

BIODEGRADABILITY

WHAT IS BIODEGRADABILITY?

1

The biodegradability and the ability of substances and organic materials to be degraded into more simple substances through the enzymatic activity of microorganisms.



2

When the biological process complete it has totally transformed the starting organic substances into simple inorganic molecules, water, carbon dioxide and methane.

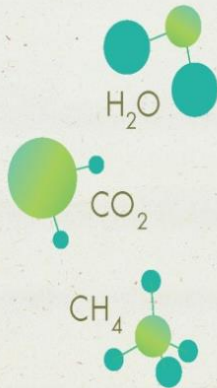

3

The phenomenon of biodegradation is part of the natural cycle of life on earth, focused on carbon.



4

Thanks to the activity of photosynthesis in plants and algae and the energy of the sun, carbon dioxide is removed from the atmosphere to synthesize sugars and substances used by plants to develop and grow.



TO SPECIFY...

BIODEGRADABILITY

WHAT IS BIODEGRADABILITY?

5

Through the food chain, matter and energy pass from the plants to herbivores and from these to carnivores. On the death of plants and animals, microorganisms feed on the organic material with processes requiring water and carbon dioxide into the atmosphere, closing the loop.



6

By mimicking these natural processes, the organic waste from human activities can be removed by biodegradation; it is possible to identify the ideal environment in which the phenomenon may develop better, in a length of the process time that is both industrialized and compatible with the rate of production of organic waste.



7

In nature, all organic waste has its biodegradation time: straw and wood will take more time than starch and cellulose. In cold and dry environments, the biodegradation processes will be slower than in hot and humid conditions.



8

The rate of biodegradation is influenced by the chemical nature of the substance or material and by the environment. The environments of industrial composting and anaerobic digestion provide for high rates of biodegradation.

TO SPECIFY...

BIODEGRADABILITY

WHAT IS BIODEGRADABILITY?

9
In composting and anaerobic digestion, one can also treat the articles (for example of biodegradable plastic) that have a biodegradation speed compatible with such treatments.

10
In the case of composting you are obtaining mature compost (which is a fertilizer), in the case of anaerobic digestion (followed by stabilization in composting) biogas is obtained (and therefore energy) along with compost.

11
Soil and other biologically active environments are where some materials can biodegrade completely, a property that can be exploited in specific applications such as mulch film.

The infographic includes the logo for MATER-BI, which consists of three stylized vertical bars in blue and green above the text 'MATER-BI' in orange. The diagrams include: 1) A pile of dark brown organic matter with an arrow pointing to a small green seedling growing from a mound of soil. 2) A green anaerobic digester tank with a yellow gas flare on top emitting light rays, with an arrow pointing up to a pile of dark brown organic matter. 3) A square brown mulch film with a grid of small green plants growing through it.

COMPOSTABLE MATERIALS...

BIOPOLYMERS

PLA

Polymers are large organic molecules made up of units that recurs along the carbon chain: they can be natural (BIOPOLYMERS) or synthetic (SYNTHETIC POLYMERS).

PLA (Polylactic Acid) is a biopolymer that derives from 100%renewable resources of vegetable origin (from corn or cassava starch, sugar cane or beet) that are used to obtain sugar molecules.

Starch (glucose) is extracted from plants and thanks to the action of enzymes and through hydrolysis glucose is converted into dextrose. Microorganisms activate dextrose fermentation to obtain lactic acid. A patented process transforms lactic acid into lactide monomer.

The polymerization process binds these monomers forming a polylactide polymer chain. The final form is PLA granules



The PLA INGENO® that ILIP uses for the realization of its compostable products is supplied by



COMPOSTABLE MATERIALS...

BIOPLASTICS

MATER-BI®

MATER-BI is an innovative material created by NOVAMONT and is part of a family of completely biodegradable and compostable bioplastics used for the realization of solutions and products for everyday life with reduced environmental impact. Mater-Bi consists of a blend of different components, some of which are from renewable resources.

MATER-BI contains:

- **CORNSTARCH.** Novamont declares that it is not genetically modified, is cultivated in Europe with traditional agricultural practices, and that no deforested land or virgin soils are used for its production.
- **VEGETABLE OILS.** Novamont declares that the vegetable oils used to produce the main raw materials of third-generation MATER-BI derives from non-transgenic crops other than palm and soy, which require little irrigation.
- **MINERAL FILLER**



MATER-BI®



Mater-bi is not a polymer but a Compound whose percentage of biobased biopolymers is around 50%.
ILIP BIO tableware made of Mater-Bi has a high temperature resistance and can also be used for hot drinks and foodstuff up to a temperature of 90°C (heat-sealable plates).

I MATERIALI COMPOSTABILI...

BIOPLASTICS

GAIA BIODOLOMER®

Biodolomer® is a high-quality mineral filled biomaterial compostable and biodegradable, containing renewable resources.

Bio
dolomer®



GAIA
BioMaterials - for a humane world

*Biodolomer® is certified compostable according to the EN13432 standard

Renewable materials in Biodolomer®:

- Calcium carbonate
- Sugar cane
- Rape seeds

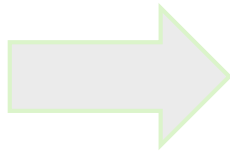

Why calcium carbonate?

Calcium carbonate contributes to the earth's natural fertility, that is why GAIA adds calcium carbonate in BIODOLOMER®.

Calcium carbonate contains traces of minerals like silica which also improves growth. Silica gives nutrition, mechanical strength, and resistance against fungal diseases.

In 2016, Gaia BioMaterials, in a joint partnership, received EU funds from the LIFE programme for a 30 MSEK project in order to show how fossil-based and energy intensive plastics and packaging materials can be replaced by Gaia BioMaterials renewable and biodegradable biomaterial Biodolomer®



GAIA - BIODOLOMER®



ILIP BIO cutlery made from BIODOLOMER® have a high temperature resistance and can also be used for hot foodstuff up to a temperature of 70°.

BIODEGRADABLE MATERIALS...

RAW MATERIAL FROM RENEWABLE SOURCES

CELLULOSE PULP



Cellulose is one of the most important polysaccharides. It consists of a large number of diglucose molecules joined together by a β -glycosidic bond. It is mainly contained in vegetables. The raw material used for the production of ILIP Bio pulp plates is bagasse, the sugar cane fiber.

PAPER

Paper is a material consisting mainly of vegetal raw materials, joined by felting and dried. Paper can be coated, with compostable plastic, or uncoated “free from plastic”.



WOOD



The wood used for the production of ILIP Bio wooden cutlery is birch from responsibly managed forests that are FSC certified (COC - Chain of Custody).



The FSC certification is internationally recognized and its purpose is the correct forest management and the traceability of derived products. The FSC® mark identifies products containing wood from forests that are managed correctly and responsibly according to strict environmental, social and economic standards.

PRODUCT FEATURES...

RESISTANCE TO TEMPERATURES



PRODUCT FEATURES...

INSTRUCTIONS FOR SHIPMENT AND STORAGE OF PLA PRODUCTS

PLA products are sensitive to high temperatures. During the summer period it is necessary to consider transports in insulated trucks and their storage in warehouses with suitable temperatures.



• AVOID HIGH TEMPERATURES

- Mark out on the boxes "product sensitive to temperature"
- Always specify the routes, shipping times, delivery dates in order to effect transports in the coolest parts of the day
- Choose insulated covers or refrigerated means of transport
- Stock under 105°F/40°C



• DO NOT LEAVE UNDER THE DIRECT SUNLIGHT

- Mark out on the boxes "product sensitive to sunlight"
- Plan just-in-time deliveries for packaging of fruit and vegetables



• STOCK ON LOWER RACKS

- Always stock in the cooler places of the warehouse
- Open the mean of transport immediately after arrival
- Do not stock near spotlights or heating points
- avoid stocking under metallic roofs or in places lacking in air circle



• HANDLE WITH CARE

- Do not leave the product loaded for long periods
- Choose the truck and shipping accessories with adequate insulated roofs
- Load and ship during the coolest part of the day
- Place the material in ad adequate place immediately after its delivery
- Ship and stock in white corrugated cartons

THE CERTIFICATIONS...

BIODEGRADABLE PRODUCTS

PAPER, PULP AND WOOD

Materials of natural origin, such as wood, wood fiber, starch, paper pulp...and relevant packaging made from these materials, are considered "biodegradable" without the need of further tests or certificates.

For example, products made of cellulose pulp (bagasse) or uncoated paper plates are included in this definition.

Instead, plates and cups coated with compostable plastic, do NOT fall into the category mentioned above and must be subjected to the European norm EN 13432.



EN 13432



The European Norm **EN 13432**, harmonized by the European Committee, determines the characteristics that a material must possess in order to be defined biodegradable and/or compostable. The term "compostable" refers to rules related to the non-toxicity of the decomposed material if dispersed in nature.

THE CERTIFICATIONS...

COMPOSTABLE PRODUCTS



The TÜV AUSTRIA group - internationally at the forefront in terms of quality, energy, environment, safety and product - in 2017 acquires the OK COMPOST certification mark and scheme from the Belgian entity Vinçotte nv. The Group's services are therefore expanded with a new product certification, which labels compostable products.



The Seedling logo is a reliable label for compostability. Along with the certification number printed on the product, the logo provides transparent information on the disposal of the packaging, thus gives assistance in the purchase of the product. The certification process is offered by the Belgian certifier TÜV Austria Belgium and by the German certifier DIN CERTCO.



The brand mainly known in Italy meets the needs of the members of CIC (Italian Composting Consortium) to clearly identify compostable products. Along with the license number the mark allows you to identify compostable materials and products.

INDUSTRIAL COMPOSTABLE



The certifiers issue the **INDUSTRIAL COMPOSTABLE** certification for products that meet the requirements of **the European Standard EN 13432 of 2002** in industrial composting processes (60°C and 90% Relative Humidity). To obtain the certification, the product must meet stringent requirements set by the standard and must be subjected to accurate laboratory analysis.

THE ILIP LICENCES

COMPOSTABLE PRODUCTS OF OWN PRODUCTION

CUPS, PLATES & CONTAINERS IN PLA



ILIP S.R.L.
007-P1096

Cup 80cc & PLATES IN M-BI



ILIP S.R.L.
058-P1096

CUPS IN PLA



7P0118

CONTAINERS IN PLA



7P0103

CUPS & PLATES IN PLA & M-BI



7P0646

CUP 200ml made of MATER-BI



7P2398





PRODUCT FEATURES...

COMPLIANCE WITH FOOD CONTACT REGULATIONS OF PLA, MATER-BI® and BIODOLOMER®

COMPLIANCE WITH FOOD CONTACT

GLOBAL OR SPECIFIC
MIGRATION ANALYSIS



INTENDED USE

Internal tests simulate the intended use of finished product that must maintain its mechanical features and original geometry

ILIP BIO PRODUCTS IN PLA:

based on their intended use, temperature and conditions of use of products in PLA are max. 40°C or room temperature for prolonged periods of time.

ILIP BIO PRODUCTS Biodolomer:

based on their intended use, temperature and conditions of use of the products are 80°C for 15 minutes.

ILIP BIO HIGH PERFORMANCE PRODUCTS (Mater-bi):

based on their intended use, temperature and conditions of use of HP products are 70°C for 2 hours (lightweight & ecodesing) - max. 80°C for 15 min. and max. 90°C for a period less than 1h.



ILIP Bio



The use of **compostable and renewable** materials makes IlipBio the most advanced solution in terms of quality and **environmental sustainability** with the guarantee and the security of compliance to the norms of compostability and food contact.

PRODUCT FEATURES...

COMPLIANCE WITH FOOD CONTACT REGULATIONS OF PULP, PAPER & WOOD

COMPLIANCE WITH FOOD CONTACT

GLOBAL OR SPECIFIC
MIGRATION ANALYSIS



INTENDED USE

Internal tests simulate the intended use of finished product that must maintain its mechanical features and original geometry



ILIP BIO PULP PRODUCTS:

based on their intended use, temperature and conditions of use of products made of pulp are max. 100°C for 30 minutes.



ILIP BIO PRODUCTS MADE OF PAPER:

based on their intended use, temperature and conditions of use of products made of paperboard and wood are max. 90°C for max. 30 min.

ILIP BIO PRODUCTS MADE OF WOOD:

based on their intended use, temperature and conditions of use of products made of paperboard and wood are max. 80°C for max. 15 min.

DISPOSAL OF THE PRODUCT AFTER ITS USE...

END OF LIFE: DIFFERENCES BETWEEN PLASTICS AND BIOPLASTICS



Since 2004 Ilip has been converting **bioplastics** to make packaging and containers to serve and pack fresh food products. All these items are **certified** and comply with **the European standard EN13432**. The life of these products ends with **organic recycling** (industrial composting) when appropriate and available and the result of this process is **compost**.

PACKAGING & INFOGRAPHIC...

CLEAR INFORMATION CONFORM TO REQUIREMENTS

Our goal is to provide correct, clear and compliant information to Italian and European regulations so that the consumer can make his conscious choice in purchasing the product.



CONDITIONS OF USE:

MAX. 100°C
FOR 30 MIN. 

DISTRIBUTED BY



MADE IN ITALY



LOT NUMBER

SUITABLE FOR HEATING IN MICROWAVE OVEN

Check with your Municipality or local waste manager how to deliver and collect waste.



The Tidy man is a pictogram designed to encourage consumers to throw packaging waste in the junk bin. The producer is not obliged by Italian law to illustrate the pictogram on the packaging, however ILIP has decided to include it on the packaging of its products because it cares about the correct disposal of the product after its use.

THE PRODCUT RANGE



THE COLOR OF THE LABEL VARIES ACCORDING TO THE RAW MATERIAL USED FOR THE PRODUCT

BIOPLASTICS: PLA, MATER-BI and BIODOLOMER®

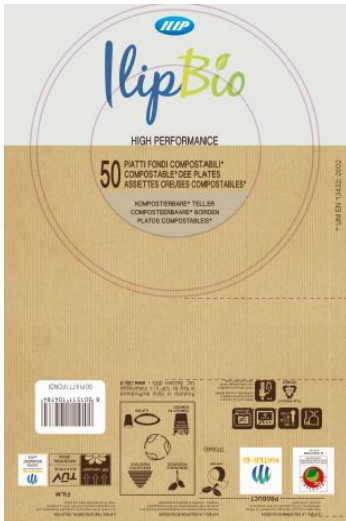

Cellulose pulp

wood

labels & film



paper



Importato e distribuito da / Imported and distributed by: ILIP S.r.l., Via Castelfranco, 52 - 40053 Valsamoggia (BO) - Italy - www.ilip.it

THE PRODUCT RANGE



CUPS IN PLA

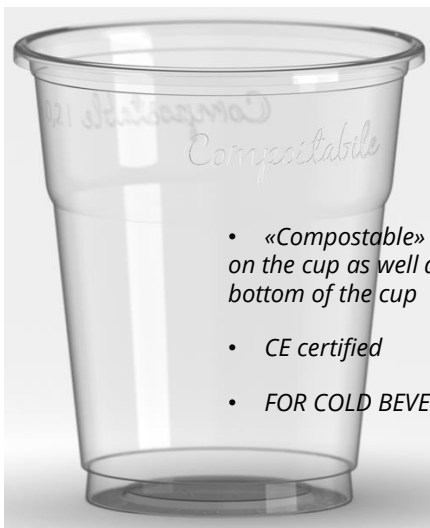

- «Compostabile» embossed on the cup as well as on the bottom of the cup
- CE certified
- FOR COLD BEVERAGES



ILIP code	SAP code	capacity/ml	CE mark ml	weight g	pcs/conf
160KPLA	60783	170	-	3,5	50
LI2001TCE	61381	200	0,2 BRIM	4,7	1
LI20050TCE	61367	200	0,2	4,7	50
LI25050TCE	61354	250	0,2	4,7	50
LI30050TCE	61353	300	0,2 FOAM 0,25	5,5	50
LI1/2PT50TCE	61466	300	½PT FOAM	5,5	50
LI35050TCE	61352	350	0,25 FOAM	7,7	50
LI4001TCEN	61560	400	0,3 FOAM	7,7	50
LI40020TCE	61431	400	0,3 FOAM	7,7	20
LI40050TCE	61364	400	0,3 FOAM	7,7	50
LI50050TCE	61360	500	0,4	8,8	50
LI57550TCE	61363	575	0,4 FOAM	11,0	50
LI1PT50TCE	61467	1PT	1 PT bordo	11,0	50
LI65050TCE	61362	650	0,5 FOAM	11,0	50

THE PRODUCT RANGE *lipBio*

LIDS FOR CUPS IN PLA

To complete the range of PLA cups, soon ILIP will offer compostable lids in PLA, in three different diameters, 78mm, 85mm and 95mm.

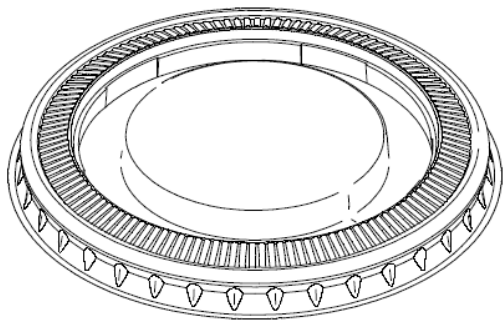

Flat lid



FOR COLD DRINKS



Available with sizes:

- Ø 78mm
- Ø 85mm
- Ø 95mm

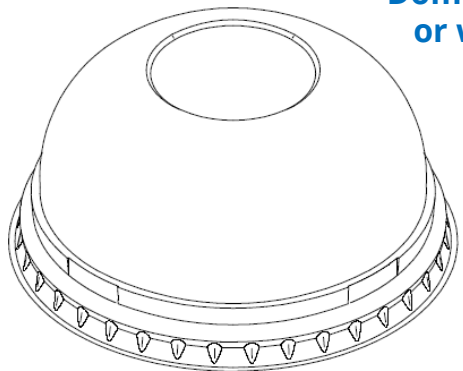

Dome lid with or without hole



THE PRODUCT RANGE



CUPS IN PLA

LIGHT CUPS



ILIP CODE	SAP CODE	capacity ml	weight g	Pcs./ pack
LI160W50TE	61602	160	2	50
LI200W1TE	61385	200	2,2	1
LI200W50TE	61412	200	2,2	50
LI230W50TE		230	2,4	50



FOR COLD BEVERAGES ONLY



TUMBLER



Codice ILIP	SAP CODE	capacity ml	CE Mark ml	weight g	pcs/ pack
LI35050TCET	61468	350	0,3	6,9	50

THE PRODUCT RANGE



PRODUCTS IN PLA

FOR COLD USE



dessert bowl



salad bowl & lid



dessert plate



cutlery

description	SAP code	seizes/ capacity	weight g	pieces/ pack	conditions of use
dessert bowl	71247 70880	Ø 12.6 cm H 4.6 cm 300ml	6	10 50	
salad bowl		18x18 h92cm	9,5	6 25	
lid		18x18 h22cm	11,5	40	
	71360			75	
dessert plate	70543	Ø 16.5 cm	5,5	20	
fork	80772	17.5 cm	4,1	25	
knife	80770	17.5 cm	3,5	25	
spoon	80771	17.5 cm	4,4	25	

THE PRODUCT RANGE



TRAYS IN PLA

THE P-LINE



FOR COLD USE



THE SH-LINE



THE G-LINE



ILIP code	SAP code	seizes	Capacity ml	weight g	conditions of use
LIP1PLA	30153	160x116xh22	250	9	
LIP2PLA	30134	191x132xh22	400	13,5	
LIP3PLA	30225	230x157xh23	600	21,5	
LIG250PLA	30116	126x117xh43	250	12	
LIG370PLA	30381	126x117xh56	370	12	
LIG500PLA	30118	135x125xh56	500	15,5	
LIG750LPLA	30119	188x143xh52	750	22	
LIG1000LPLA	30015	188x143xh67	1.000	25	
LISH20PLA	30092	217x167xh20	570	20,5	
LISH35PLA	30094	217x167xh35	1.000	23	
LISH55PLA	30096	217x167h55	1.500	28,5	

LA GAMMA...

lipBio

CUPS IN MATER-BI

HIGH PERFORMANCE



80ml

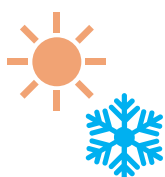

200ml



MAX
80°C
15 min.



MAX
70°C
2h

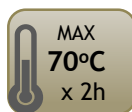

MAX
70°C
x 2h



Compostable and high-performing cups for cold and hot drinks

ILIP code	SAP code	capacity	weight	pcs/ pack
LI8040	61540	80ml	2,5g	40
LI200W50	61550	200ml	3,5g	50

THE PRODUCT RANGE



PLATES MADE OF MATER-BI

flat plate

deep plate



eco-design
Ø20, 13g

light-weight &
HIGH PERFORMANCE

Ø21, 14g & 16g



Compostable high-performing plates for cold and hot food.



description	code	seizes	weight	Pcs/ pack	line	conditions of use		
flat plate		Ø 20 cm	13g	12	<i>eco-design</i>			
				20				
deep plate		Ø 20 cm	13g	12				
				20				
flat plate	71370	Ø 21 cm	14g	12	<i>light-weight</i>			
	71380			25				
deep plate	71371	Ø 21 cm	14g	12				
				25				
flat plate	71022	Ø 21 cm	16g	25			HIGH PERFORMANCE	
	71262			50				
deep plate	71023	Ø 21 cm	16g	25				
	71264			50				

THE PRODUCT RANGE

lipBio

PLATES MADE OF MATER-BI

HIGH PERFORMANCE



oval plate



bowl



Pizza plate



Compostabile high-performing plates for cold and hot food



description	code	seizes	weight	Pcs/ pack	conditions of use	
oval plate	71315	26x19 cm	16g	10		
oval plate	70805	26x19 cm	16g	25		
bowl	71265	Ø 16,5 cm	16g	12		
bowl	71257	Ø 16,5 cm	16g	25		
pizza plate	tbc	Ø 31,5 cm	32g	8		

THE PRODUCT RANGE



HEAT-SEALABLE PLATES IN MATER-BI

HIGH PERFORMANCE

Ilip has developed a new line of heat-sealable compostable plates with a high thermal resistance.



DESCRIPTION	SAP CODE	SEIZES cm	HEIGHT cm	WEIGHT g	
flat plate	71153	18x18 	2.5	18	40
					800
deep plate	71171		3.5	18	40
					800
deep plate, 2 compartments	71172		4	22	40
					800
lid	71360	0,55	11,5	40	
				75	



**RESISTANCE TO TEMPERATURE:
MAX. 90°C for < 1h**



The plates can be closed with a **rigid lid in PLA** that resists to temperatures from -20 to +40°C, or they can be

heat-sealed with **film in PLA** of different widths.



ILIP CODE	SAP CODE	WIDTHS
LIFANP185	79000	185 mm
LIFANP220	79002	220 mm
LIFANP370	79010	370mm
LIFANP420	79001	420 mm

Suitable to come into contact with food-stuff at room temperature or below.



THE PRODUCT RANGE



COMPOSTABLE CUTLERY



HIGH PERFORMANCE

description	ILIP code	SAP code	length mm	weight g	pcs/ pack	use cond.
dessert spoon	LICND40	80901	120	2,3	40	
	LICND100	80570			100	
Bis fork-knife + napkin	LIBIS+T	80840	170	12,6	250	
Tris fork-knife-spoon + napkin	LITRIS+T	80841	170	17,9	200	



HIGH PERFORMANCE

description	ILIP code	SAP code	length mm	weight g	pcs/ pack	use cond.
fork	LIFO25MB	80827	175	3,2	25	
knife	LICO25MB	80828	175	3,2	25	
spoon	LICU25MB	80829	175	4,0	25	



THE PRODUCT RANGE





CELLULOSE PULP

Ilip has included a wide range of **biodegradable** products made of cellulose pulp. The raw material used is bagasse, the sugar cane fiber, the place of production is PRC.



16 products in packs of 50 pcs

descrizione	ILIP code	SAP code	seizes/capacity	conditions of use
Flat plate M-XL	LIPP50 LIPP50XL	71187 71186	Ø 22 cm Ø 26 cm	<p>Suitable to contain cold and hot food up to 100°C</p> <p>MAX 100°C 30 min.</p> <p> </p> <p>Suitable for heating in microwave oven but not for cooking.</p> <p></p>
Deep plate	LIPF50	71240	Ø 19 cm 680ml	
bowl	LISC50	71182	Ø 17,5 cm 400ml	
Ovale plate L-XL	LIPOV50 LIPOV50XL	71189 71188	26 x 20 cm 31,8 x 25,5 cm	
Square plate S-M-XL	LIPPQ50S LIPPQ50M LIPPQ50XL	71185 71204 71184	16 x 16 20 x 20 26 x 26	
Rectangular plate	LIPPR50	71183	26 x 13 cm	
Dessert plate	LIPND50	71200	Ø 17,5 cm	
Plate 2 compartments	LIP2S50	71203	Ø 22 cm	
Plate 3 comp. M-XL	LIP3S50 LIP3S50XL	71202 71201	Ø 23 cm Ø 26 cm	
Catering tray 5 compartments	LIVS5	30570	26,5 x 21,5 x 2,5 cm	
tray	LIVS173	30572	17,5 x 12,2 x 4 cm	

THE PRODUCT RANGE *lipBio*



CELLULOSE PULP

lip has included a wide range of **biodegradable** products made of cellulose pulp. The raw material used is bagasse, the sugar cane fiber, the place of production is PRC.



**7 ITEMS
in 15 count
packs**



description	ILIP code	SAP code	seizes/capacity	conditions of use
Flat plate M	LIPP15	71233	Ø 22 cm	<p>For hot and cold use</p>  <p>Suitable for heating in microwave oven but not for cooking.</p> 
Deep plate	LIPF50	71241	Ø 19 cm 680ml	
Dessert plate	LIPND50	71234	Ø 17,5 cm	
Ovale plate L	LIPOV15	71242	26 x 20 cm	
Square plate S-M-XL	LIPPQ50S LIPPQ50M LIPPQ50XL	71243 71245 71244	16 x 16 20 x 20 26 x 26	

CELLULOSE PULP



Cellulose is one of the most important polysaccharides. It consists of a large number of diglucose molecules joined together by a B-glycosidic bond. It is mainly contained in vegetables such as sugar cane.

THE RANGE ...

IlipBio

CELLULOSE PULP

To complete the range of containers for catering and restaurant professionals, Ilip will insert a range of **biodegradable** clamshell containers in cellulose pulp.





NEW ITEMS
1° QUARTER
2021



CONTAINERS FOR
HOT AND COLD USE



8 REFERENCES
in packs of 50pcs

Codice ILIP	capacità	peso/g	misura	temperatur a d'uso
LICP450	450	24	155X155X77	 <p>Suitable for heating in microwave only and not for cooking.</p>  
LICP600	600	20	182X136X68	
LICP1000Q	1000	37	220X203X76	
LICP1000Q3S	325 / 70 / 60	37	220X203X76	
LICP1200	1200	42	228X228X76	
LICP12003S	350 / 120 / 120	42	228X228X76	
LICP1000R	1000	30	230X153X80	
LICP1000R2S	500 / 300	30	230X153X80	

THE PRODUCT RANGE

IlipBio

CARDBOARD

Ilip has included in its ILIP BIO offer a range of paper products consisting of cups, plates and a tray in packs of 20 and 50 pieces.

The raw material used is 100% renewable, pure Scandinavian virgin cellulose fiber produced from wood from responsibly managed forests and **FSC certified (COC - Chain of Custody)**. The products are made in EUROPE.

The cups are made of paper with a water-based dispersion Barrier of organic polymers, are **free from plastic film, biodegradable** and can be disposed in the paper waste sorting.



Since the plates are not chemically modified, they are considered naturally biodegradable and resistant to liquids and fats.

Plates and cups can be used for cold and hot food and drinks up to a temperature of 90°C.



Cardboard
for hot and cold
foods and beverages



THE PRODUCT RANGE



PAPER CUPS WITH WATER DISPERSION COATING*

The cups made from cardboard “free from plastic film” are biodegradable, recyclable and can be disposed of in the paper recycling bin.



FOR COLD AND HOT USE



ILIP CODE	SAP CODE	CAPACITY	WEIGHT g	pcs/ pack	CONDITIONS OF USE
LI12050P	61510	4oz 120 ml	2,75	50	
LI18050P	61511	6oz 180 ml	4,3	50	
LI25050P	61512	8oz 250 ml	6,8	50	
LI35050P	61513	12oz 350 ml	10,3	50	



PRINTABLE – CUSTOMIZABLE

...TO COMPLETE THE RANGE...

LIDS IN PS FOR THE PAPER CUPS

To complete the range of paper cups, Ilip offers recyclable polystyrene lids in two diameters, to be disposed of in the plastic bin.



FOR HOT AND COLD
DRINKS



ILIP CODE	SAP CODE	FITS PAPER CUP	WEIGHT g	Pcs/ pack	USE CONDITIONS
LIC120	61580	120 ml	1,30	100	
LIC250	61581	250 ml	2,12	100	

SPECIFICATION

WATER DISPERSION COATING

Biodegradability and recyclability

The paper with an aqueous dispersion coating is biodegradable according to the European standard EN13432:2000 up to 90% in 105 days and is recyclable and «repulpable» to 94,7% like normal uncoated paper.

RECYCLING A DISPOSABLE PAPERBOARD COFFEE CUP

TRADITIONAL CUPSTOCK WITH PE COATING

SEPARATELY COLLECTED AND SORTED. REQUIRES OWN COLLECTION SYSTEM.

WHEN CUPS ARE SHREDDED, FIBRES MUST BE SEPARATED FROM THE PE LAYER BEFORE TRANSFORMED INTO PULP.

A CUP MADE FROM ISLA BARRIER CUPSTOCK WITH DISPERSION COATING

RECYCLED WITH NORMAL PAPER AND BOARD WASTE. DOES NOT REQUIRE OWN COLLECTION SYSTEM.

PAPER WASTE AND CUPS ARE SHREDDED INTO PIECES AND TRANSFORMED INTO PULP.

6/27/2018 © Salla Kettunen, Kotkamills Oy INTERNAL MATERIAL THE GAME CHANGER **KOTKAMILLS**

FREE FROM PLASTIC FILM

Microplastic materials

There are a number of definitions, official and non-official about what should be regarded as a microplastic material. A frequently used definition is that microplastics are solid plastic materials with a diameter of less than 5 mm.

Proposal for a EU directive to address the most important sources of microplastics has been made by the European Chemicals Agency (ECHA). In this proposal, the intentional use of microplastic in a number of everyday products is to be banned.

In the board used to produce our products there are no intentionally added primary microplastics.

Presently, there is no legislation and no clearly defined analytics or restrictions regarding non-intentionally formed microplastics.

SPECIFICATION

*WATER DISPERSION COATING

The nature of the water dispersion coatings

The aqueous dispersion of organic polymers, generally called "lactic acids", which are mixtures of natural and synthetic polymers, are widely used in the paper industry as coatings, binders, colours or adhesives. The "lactic acids" do not have a melting point and are unable to perform the function of the main structural component of the finished product and do not have the stretching properties like the plastic has. Generally, these polymers are also mixed with «fillers» and additives to give them the expected functionality. For the production of the cups they only serve as a barrier to liquids and fats and as adhesives.



Thanks to these characteristics, they cannot be classified as plastics according to the definitions used by both the European Plastics Directive 10/2011 and the European Directive on S.U.P. 2019/904. Consequently, products made with paper with aqueous dispersion coating are not covered by the S.U.P. Directive *

Interpretation of the paper manufacturer

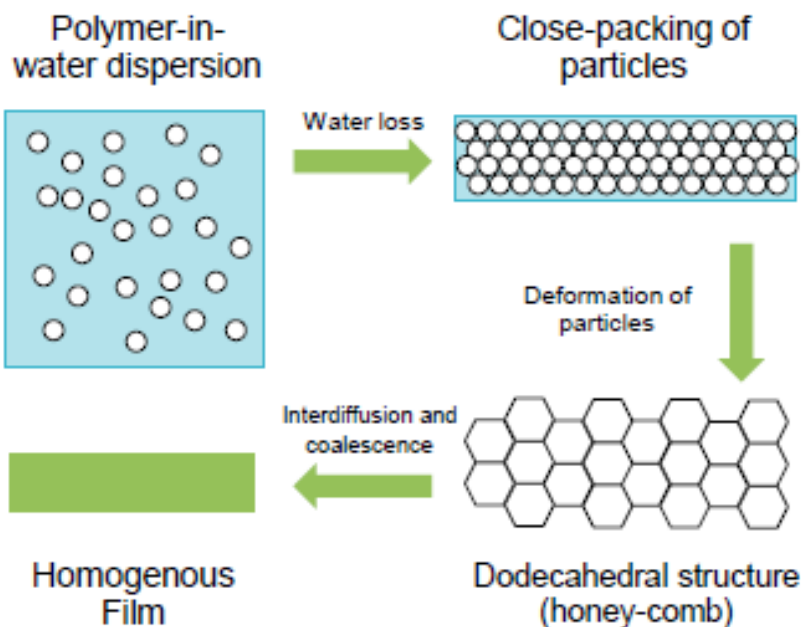

THE PRODUCT RANGE



UNCOATED PAPER PLATES

Ilip offers a range of biodegradable plates made from uncoated PAPER, resistant to liquids and fats that can be used with cold and hot foods.



flat plate
Ø 23 cm

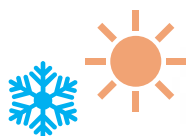

Cardboard.
For hot and cold foods.



tray
190x110 cm



dessert
plate
Ø 18 cm



Pizza plate
Ø 32 cm



«High Quality Certified Paper»

free from plastic

description	seizes cm	pcs/pack	Conditions of use
flat plate	Ø 23	20 50	
dessert plate	Ø 18	20 50	
pizza plate	Ø 320	20 50	
tray	190x110 h30	50	

THE PRODUCT RANGE



WOODEN CUTLERY

Ilip offers a range of cutlery made of wood, packaged in 20 and 100 pieces. The cutlery derive from 100% renewable resources, is biodegradable, sustainable and is made of birch wood from responsibly managed forests that are FSC certified (COC - Chain of Custody). The Ilip Bio wooden cutlery can be used for cold and hot foodstuff and can withstand temperatures up to 70°C degrees for max. to 2 hours.



description	SAP code	length mm	weight g	Pcs/pack	conditions of use
fork	80814 80813	160	2,5	20 100	
kinfe	80816 80810	160	2,5	20 100	
spoon	80815 80812	160	3,0	20 100	
dessert spoon	80817 80811	110	2,0	20 100	
set bis	80820	160	7,0	50	
coffee stirrer	80821	90	0,7	100	
stirrer sing. packed	80822	90	0,45	100	

THE CERTIFICATIONS...

OF THE ILIP BIO RANGE

BRC CERTIFICATE

Certificate No.: 35186-2008-ABRC IOP-ITA-ACCREDITA	Initial Audit date: 2008-06-18	Certificate expiry date: 2021-02-25
	Audit date: 2020-03-07	Re-audit due date: from 2020-12-17 to 2021-01-14

This is to certify that the processing activities of

ILIP S.r.l.

Production site: Via Castelfranco, 52 - 40053 Valsamoggia, loc. Bazzano (BO), Italy
 Warehouse: via Muzza Spadetta 36/38 - 40053 Valsamoggia, loc. Bazzano (BO), Italy
 Warehouse: via delle Industrie 59/61 - 41013 Castelfranco Emilia, loc. Piumazzo (MO), Italy

BRC site code: 1954055

has been found to conform to the standard:
GLOBAL STANDARD FOR PACKAGING AND PACKAGING MATERIALS ISSUE 5: JULY 2015

Audit programme: **announced**

The certificate is valid for the following scope:

Extrusion and thermoforming of containers, lids, trays, fruit nest trays for food packaging and disposable tableware (plates, glasses) made in PP, PET, PS, compostable biopolymers. Outsourced processes: off-set decoration and packing of plastic cups; punnets handle application; packing of plastic cups (one single piece per bag), application of pad and bubble pad in punnets.

Estrusione e termoformatura di contenitori, coperchi, vassoi e alveoli per il confezionamento di alimenti e di stoviglie monouso (piatti, bicchieri) in PP, PET, PS, biopolimeri compostabili. Processi externalizzati: decorazione offset e confezionamento di bicchieri in plastica; applicazione manico ai cestini; confezionamento di bicchieri in plastica in confezione singola, applicazione di pad assorbenti e microbolle in cestini.

Packaging Category: **High hygiene**
 Fields of audit: **04 - Rigid plastics**
 Including voluntary modules of: **N/A**
 Exclusion from scope: **Factored goods**
 Achieved grade: **GRADE A**
 Auditor number: 053006

<p>Place and date: Vimercate (MB), 2020-02-11</p>		<p>For the Accredited Unit: DNV GL Business Assurance Italia S.r.l.</p> <p>Sabrina Bianchini Management Representative</p>
---	--	--

Lack of fulfillment of conditions as set out in the Certification Agreement may render this Certificate invalid. Any changes in the product shall immediately be reported to DNV GL Business Assurance Italia S.r.l. in order to verify whether this Certificate remains valid. This certificate remains the property of Accredited Unit: DNV GL Business Assurance Italia S.r.l., Via Energy Park, 14, 00072 Vimercate (MB), Italy. Tel. +39 0362 86 800. Web site: www.dnvgl.com/assurance To withdraw certificate authority, The BRC logo belongs to the British Retail Consortium, who grants the use under license. If you would like to feedback comments on the BRC Global Standard or the audit process directly to BRC, please contact brc@brcglobal.com



ILIP MEMBER / PARTNERSHIPS





Passion for packaging

ILIP SRL

A business of Ilpa Group



via Castelfranco 52
40053 Valsamoggia BO
tel +39 0516715411 - fax
+39 051 6715413
info@ilip.it - www.ilip.it